

POWER CORD 2500/2000 LONG OUTSIDE
 (PLUG WITH EARTH WIRE)

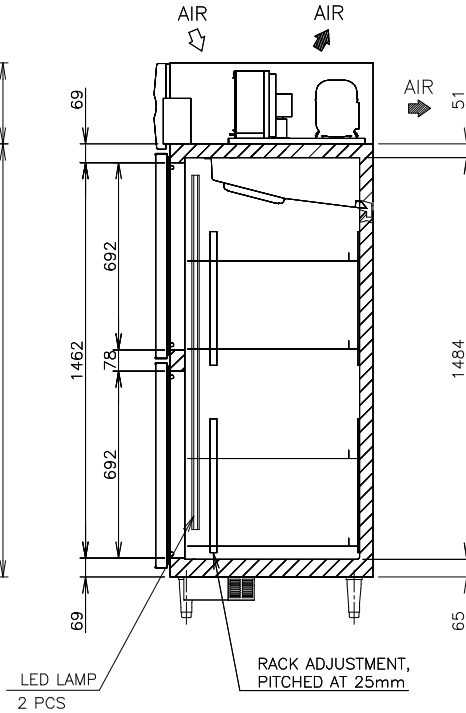
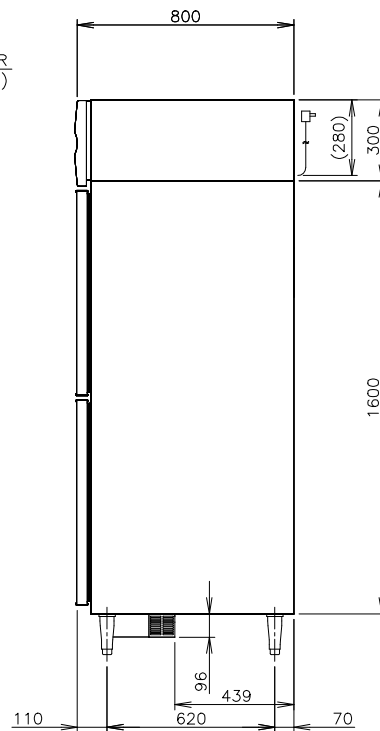
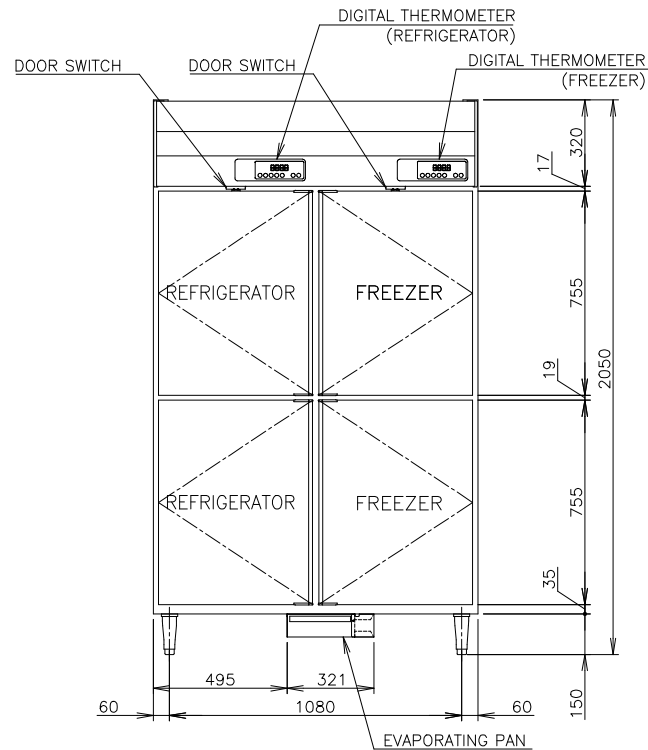
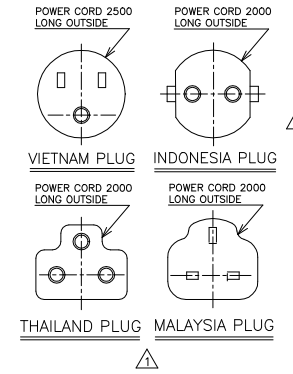
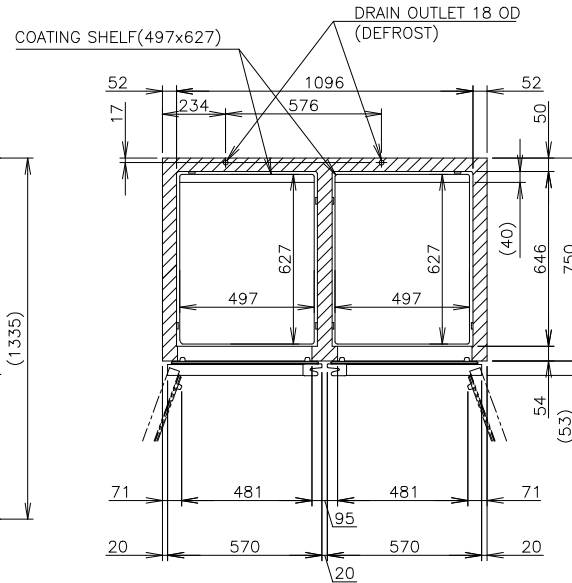
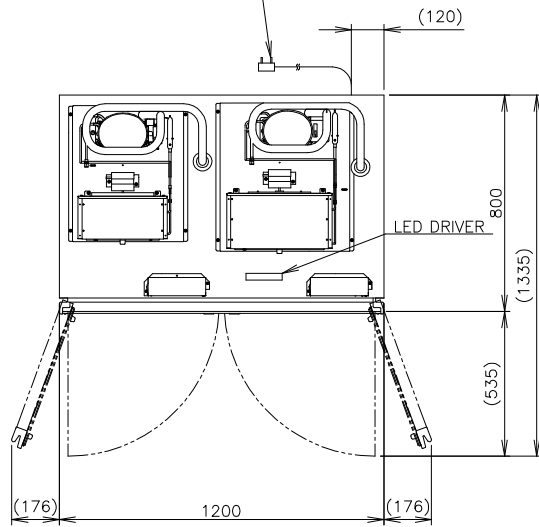

ITEM	Hoshizaki Reach-in Freezer/Refrigerator	
MODEL	HRF-128MC-S	
POWER SUPPLY	1 Phase 220~240V 50Hz Capacity: 2.16kVA (5.10A)	
AMPERAGE	Rated: 5.6A	
ELECTRIC CONSUMPTION	MOTOR 605W(POWER FACTOR 78%) Heater 627W Refrigeration 751W Defrost 400W	
HEAT REJECTION	1762W	
POWER CORD	Plug with Earth Wire	
EFFECTIVE CAPACITY	Total 976L (Refrigerator: 488L, Freezer: 488L)	
OUTSIDE DIMENSIONS	1200mm(W) x 800mm(D) x 2050(-2080)mm(H)	
INSIDE DIMENSIONS	Refrigerator	521mm(W)x646mm(D)x1484mm(H)
	Freezer	521mm(W)x646mm(D)x1484mm(H)
EXTERIOR	Stainless Steel, Galvanized Steel(Top, Rear, Bottom)	
INTERIOR	Stainless Steel, ABS Plastic(Door)	
INSULATION	Polyurethane Foam	
INSULATION FOAM BLOWING AGENT	Cyclopentane	
REFRIGERATION SYSTEM	Forced Air Circulation	
DEFROST SYSTEM	Refrigerator	Heater
	Freezer	Heater
COMPRESSOR	Refrigerator	Hermetic
	Freezer	Hermetic
CONDENSER	Refrigerator	Wire and Tube Type, Air-cooled
	Freezer	Wire and Tube Type, Air-cooled
EVAPORATOR	Refrigerator	Fin and Tube type
	Freezer	Fin and Tube type
REFRIGERANT	Refrigerator	R290
	Freezer	R290
TEMPERATURE CONTROL	Refrigerator	Microprocessor Controlled (Digital Temperature Indication) Adjustable from -6 to 12°C
	Freezer	Microprocessor Controlled (Digital Temperature Indication) Adjustable from -25 to -7°C
DEFROST CONTROL	Microprocessor	
ELECTRIC CIRCUIT PROTECTION	Earth Wire, Circuit Breaker	
REFRIGERANT CIRCUIT PROTECTION	Motor Protector (Auto-reset)	
LEG	Plastic Adjustable from 150 to 180mm	
SHELF	8 pcs.	
WEIGHT	166kg (Gross 195kg)	
PACKAGE	Carton (Wooden Pallet) 1260mm(W) x 900mm(D) x 2075mm(H)	
ACCESSORIES	Drain Hose x 1, Drain Pan x 1	
OPERATING CONDITIONS	Ambient Temperature: 5 - 38°C Voltage Range: Rated Voltage ±6%	

*We reserve the right to make changes in specifications and design without prior notice.

1. Install the product properly in accordance with the instructions on location, water supply/drain connections and electrical connections stated in the instruction and installation manuals provided.
 Allow 10mm extra space at the installation site to meet any installation requirements (additional spacing is also required for proper air flow and pipe connections).
2. The heat rejection is based on the reached pulldown temperature at ambient temperature of 35°C
3. Product Code: S183-V100 HVN, S183-V200 HID, S183-V300 HTH, S183-V400 HMY

HOSHIZAKI REACH-IN FREEZER/REFRIGERATOR HRF-128MC-S

APPROVED LIANG	CHECKED LIANG	DESIGNED LXF	DRAWN LXF	SCALE 1/20	TRIGONOMETRY
LIANG	LY	2025.11.28	DATE	2025.06.05	DRAWING NO. D42547
APPROVED	DESIGNED	DATE			SYMBOL